

# BLT421 Product Manual

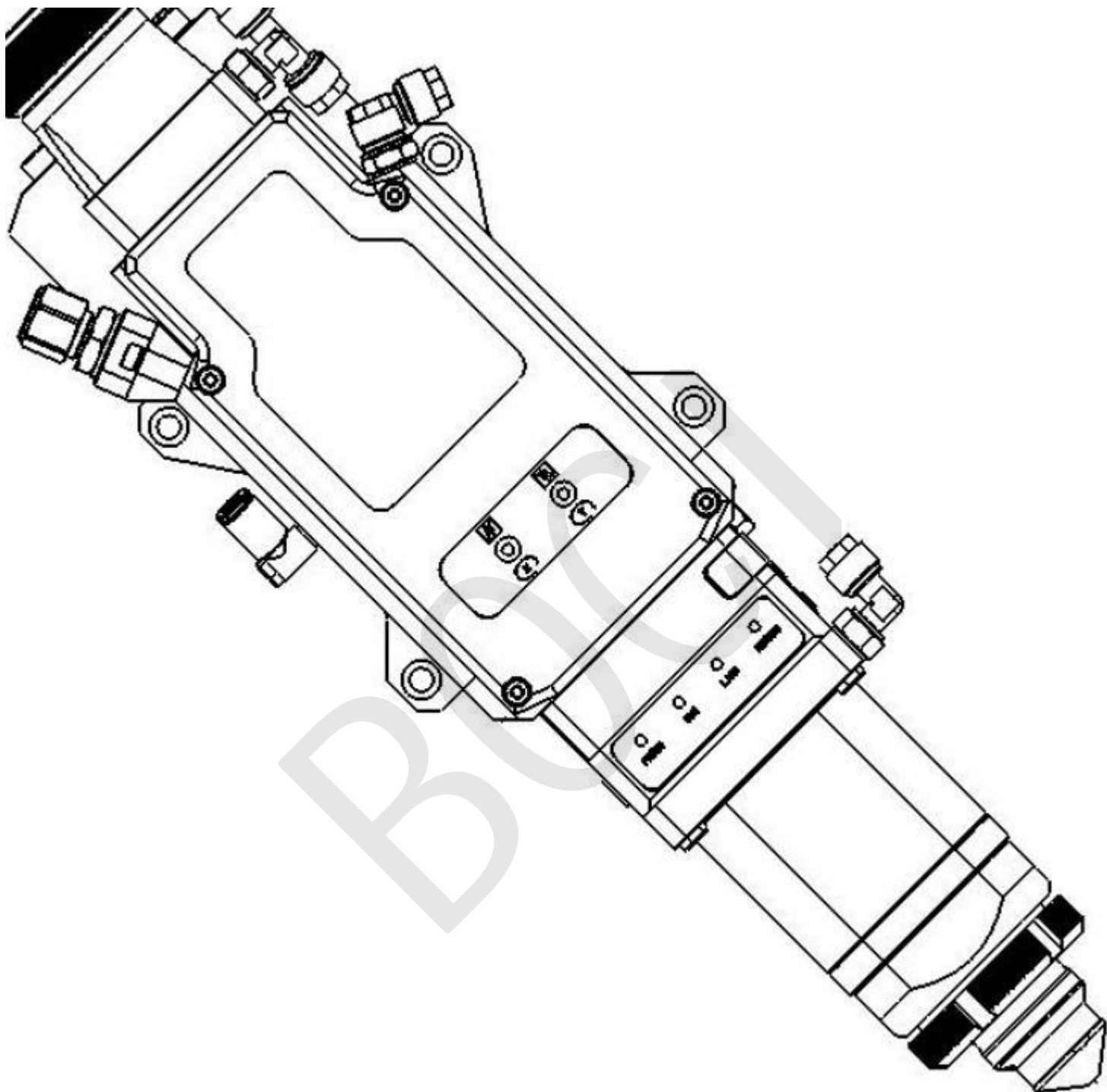

Excellent Optical Cutting Instrument

## Document History

Number	Date	Version
01	2022/08/19	V1.1

### Notice:



Thank you for choosing the BLT intelligent cutting head. This manual provides you with important information such as product parameters, installation, and maintenance, so please read this manual carefully before using the product. At the same time, in order to ensure the safety of operation and the operation of the product in the best condition, please strictly follow the precautions in the manual.

BOCI is constantly updating/upgrading products, so our company reserves the right to modify the product models and descriptions in this manual without prior declaration.

**Unauthorized disassembly of the product is strictly prohibited without the authorization of BOCI Technology, otherwise the warranty will be invalid!**

# Table of contents

BLT421 Product Manual .....	1
1. Product Description .....	1
1.1 Product View .....	1
1.2 Technical parameters .....	2
1.3 Meaning of LED indicator .....	3
2. Gas port .....	4
3. Water cooling interface .....	5
4. Electrical interface .....	6
4.1 Bus system .....	7
4.2 Non-bus systems .....	8
5. Cutting head installation .....	9
5.1 Preparation before operation .....	9
5.2 Specific operation process .....	10
5.2.1 Preparation of clean bench .....	10
5.2.2 The cutting head is placed in the clean workbench .....	10
5.2.3 Clean and wipe the fiber interface of the cutting head .....	11
5.2.4 Check the laser fiber end face .....	11
5.2.5 Tear off the protective film/remove the protective cap .....	11
5.2.6 Insert the laser fiber interface into the cutting head .....	12
5.2.7 Winding seal .....	12
5.2.8 Mount the cutting head on the backplane .....	13
5.2.9 Installing the ceramic body and nozzle .....	14

5.2.10 Beam centering ..... 15

Appendix A - Care/Maintenance ..... 17

1.1 Schematic diagram of product structure ..... 17

1.2 Replace the upper protective lens ..... 18

1.3 Replace the lower protective lens ..... 19

Appendix B - Mechanical Dimensions ..... 20

1.1 Cutting head installation size ..... 20



# 1. Product Description

## 1.1 Product View

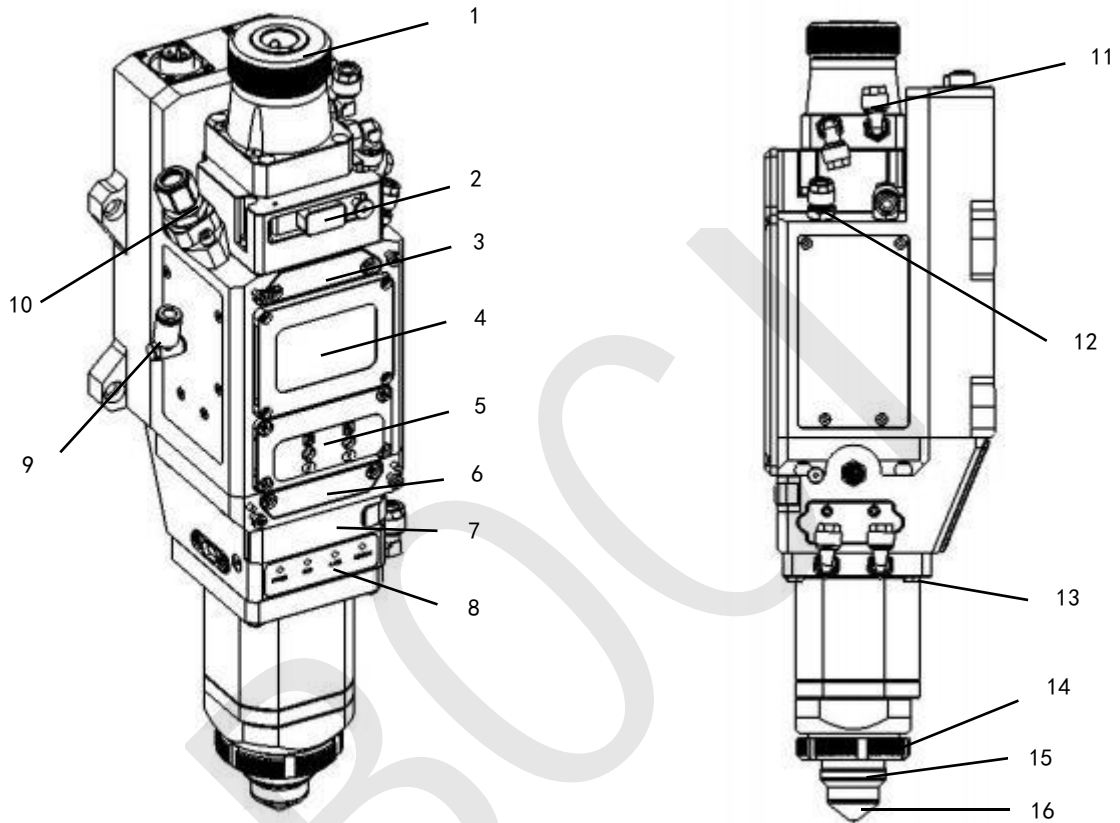

Product View (Structure and Interface Description)

- |   |                                  |
|---|----------------------------------|
| 1. Optical fiber interface;               | 9. Nozzle cooling air interface; |
| 2. 1 <sup>st</sup> Upper protective lens; | 10. Cutting gas interface;       |
| 3. 2 <sup>nd</sup> Upper protective lens; | 11. Cooling water outlet;        |
| 4. Collimation unit;                      | 12. Cooling water inlet;         |
| 5. Focusing unit;                         | 13. Anti-collision screw;        |
| 6. 2 <sup>nd</sup> Lower protective lens; | 14. Ceramic body lock ring;      |
| 7. 1 <sup>st</sup> Lower protective lens; | 15. Ceramic body;                |
| 8. Working indicator;                     | 16. Nozzle;                      |

## 1.2 Technical parameters

Cutting head	BLT421
Laser wavelength:	1030-1090nm
Laser power:	≤8kW
Fiber interface:	QBH, EOC
Spot magnification:	M=1.5/2.0 (100:150/100:200)
Focus adjustment range:	±50mm (optical ratio 1:2 100:200)
NA:	Max.0.13 at Fc100
Centering adjustment range:	±1.5mm
Focus acceleration:	7.5m/s <sup>2</sup>
Cutting gas interface:	ø10, maximum 25bar (2.5Mpa)
Nozzle cooling gas connection:	ø6, maximum 5bar (0.5Mpa)
Water cooling interface:	ø8, maximum 5bar (0.5Mpa), minimum flow 2.0l/min
Operating temperature:	5 ~ 55°C
storage temperature:	-25 ~ +55 °C
size:	404x122
weight:	About 5.5kg





**Notice:**

To avoid damage to the cutting head during storage and transportation, pay attention to the following:

- The cutting head should be stored within the allowable temperature and humidity range.
- Avoid storage in and near magnetic fields such as permanent magnets or strong alternating fields.
- Avoid collision of the cutting head.

### 1.3 Meaning of LED indicator

icon	state	meaning
<b>POWER</b> 	green	Power is normal.
	red	Under-voltage alarm: insufficient electrical power.
	not bright	No power supply: There is no power supply, the connection cable is broken, and the interface is loose.

icon	state	meaning
<b>RUN</b> 	green	The system is operating normally.
	red	Abnormal motor: The current consumption of the motor is too large, and the mechanical components cannot run smoothly.
	not bright	The cable is broken, and the interface is loose.

icon	state	meaning
<b>LINK</b> 	green	System communication is normal.
	red	System communication is abnormal.
	not bright	The cable is broken, and the interface is loose.

icon	state	meaning
<b>SENSOR</b> 	green	The readings of each sensor are normal.
	red	There is an abnormal sensor reading.
	not bright	The cable is broken, and the interface is loose.

## 2. Gas interface

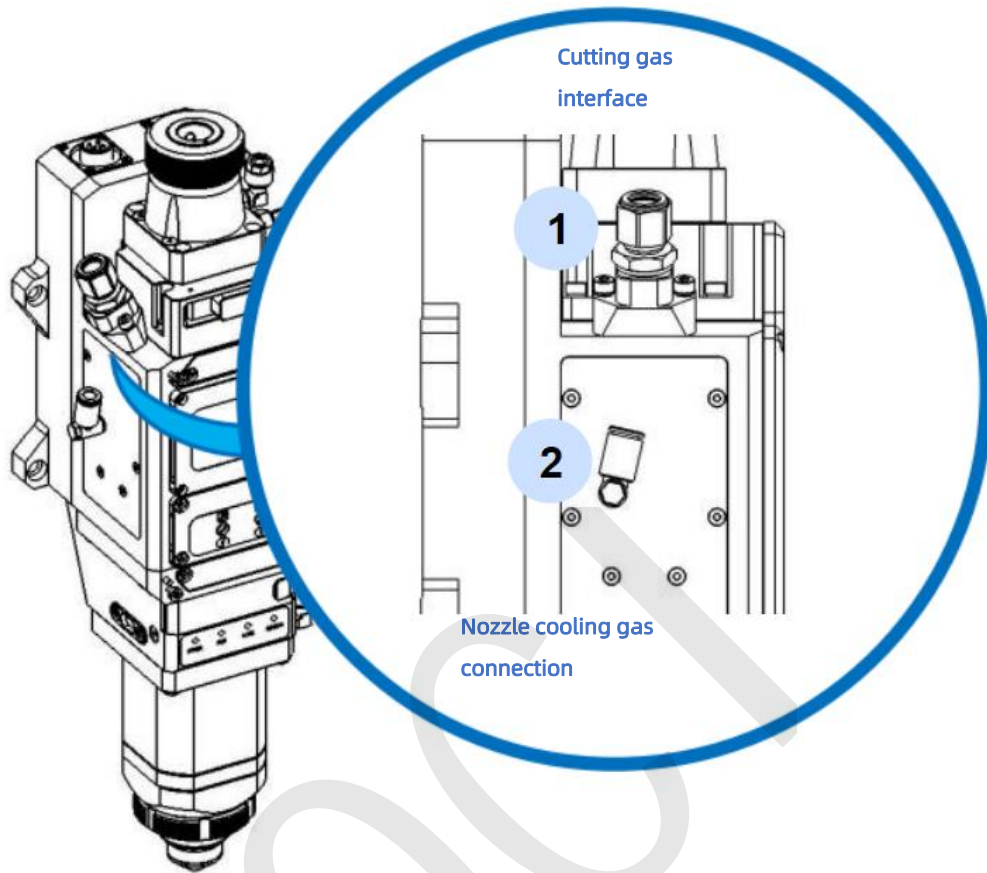

Installation connection: cutting gas 1, nozzle cooling gas 2

### Notice:



- ◆ The maximum pressure of cutting gas is 25bar (2.5Mpa).
- ◆ The cutting gas quality shall meet the requirements of gas quality in accordance with ISO 8573-1:2010: solid particles - class 2, water - class 4, oil - class 3. The purer the cutting gas, the longer the life of the protective lens.
- ◆ The cutting gas pipe diameter (outer diameter) is 10mm, and the nozzle cooling gas pipe diameter (outer diameter) is 6mm.



### 3. Water cooling interface

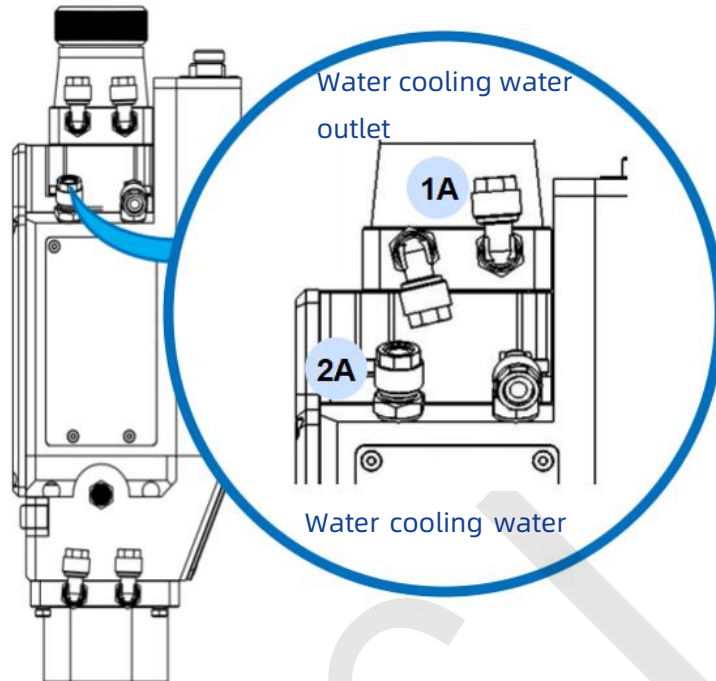

Installation connection: water-cooled water inlet port 2A, water-cooled water outlet port 1A

**Notice:**

- ◆ Deionized/distilled water (conductivity < 10 μS/cm) specified by the laser manufacturer is recommended.
- ◆ Recommended cooling water setting value: cooling water pressure ≤5bar (0.5Mpa), water flow rate ≥ 2.0l/min.
- ◆ Please refer to the dew point table to set the cooling water temperature to prevent condensation on the optical components.

Dew point temperature at different temperature and humidity

空气温度 °C	相对湿度%																		
	100	95	90	85	80	75	70	65	60	55	50	45	40	35	30	25	20	15	10
43	43	42	41	40	39	38	37	35	34	32	31	29	27	24	22	18	16	11	5
41	41	39	38	37	36	35	34	33	32	29	28	27	24	22	19	17	13	8	3
38	38	37	36	35	34	33	32	30	29	27	26	24	22	19	17	14	11	7	0
35	35	34	33	32	31	30	29	27	26	24	23	21	19	17	15	12	9	4	0
32	32	31	31	29	28	27	26	24	23	22	20	18	17	15	12	9	6	2	0
29	29	28	27	26	24	23	22	21	19	18	16	14	12	10	7	3	0		
27	27	26	25	24	23	22	21	19	18	17	15	13	12	10	7	4	2	0	
24	24	23	22	21	20	19	18	17	16	14	13	11	9	7	5	2	0		
21	21	20	19	18	17	16	15	14	13	12	10	8	7	4	3	0			
18	18	17	17	16	15	14	13	12	10	9	7	6	4	2	0				
16	16	14	14	13	12	11	10	9	7	6	5	3	2	0					
13	13	12	11	10	9	8	7	6	4	3	2	1	0						
10	10	9	8	7	7	6	4	3	2	1	0								
7	7	6	6	4	4	3	2	1	0										
4	4	4	3	2	1	0													

## 4. Electrical Interface



PWE and aviation plug interface waterproof precautions:

1. PWE interface and air plug interface are equipped with dust plugs from the factory. If the dust plug does not fall off, the protection level of IP64 can be achieved; at the same time, when the PWE cable and the air plug cable are well connected, IP64 can also be achieved;
2. After the dust plug is removed, the protection level of IP64 cannot be achieved. If it encounters spraying or flushing at this time, it will cause water to enter the product and affect the function;
3. Ensure that the water circuit is connected well, and the water pipe interface is tightened before removing the dust plug to prevent the water pipe from accidentally loosening and water rushing to the interface, causing the product to enter the water;
4. When adjusting the wiring, remove the dust plug for wiring. It is recommended to keep the removed dust plug of the PWE interface. Install the dust-proof plug as soon as possible after the stitches are removed to prevent accidental water ingress in the transfer, water connection and other links.

4.1 Bus system

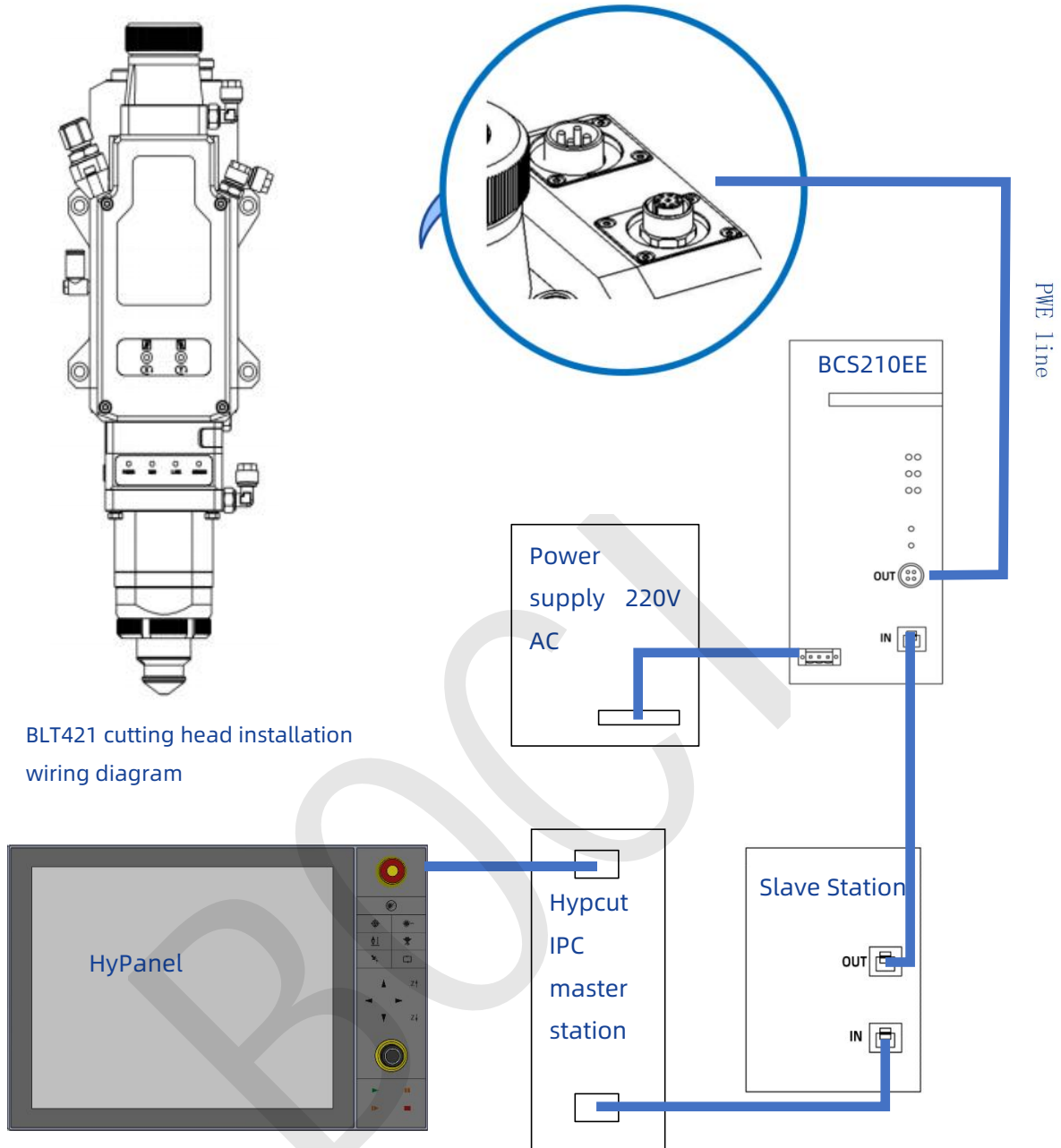

BLT421 cutting head installation wiring diagram



**Notice:**

- ◆ The above wiring operations should only be performed by trained and professional personnel.
- ◆ When the cutting head is connected to the BCS210E, the BCS210E must be powered off.

4.2 Non-bus systems

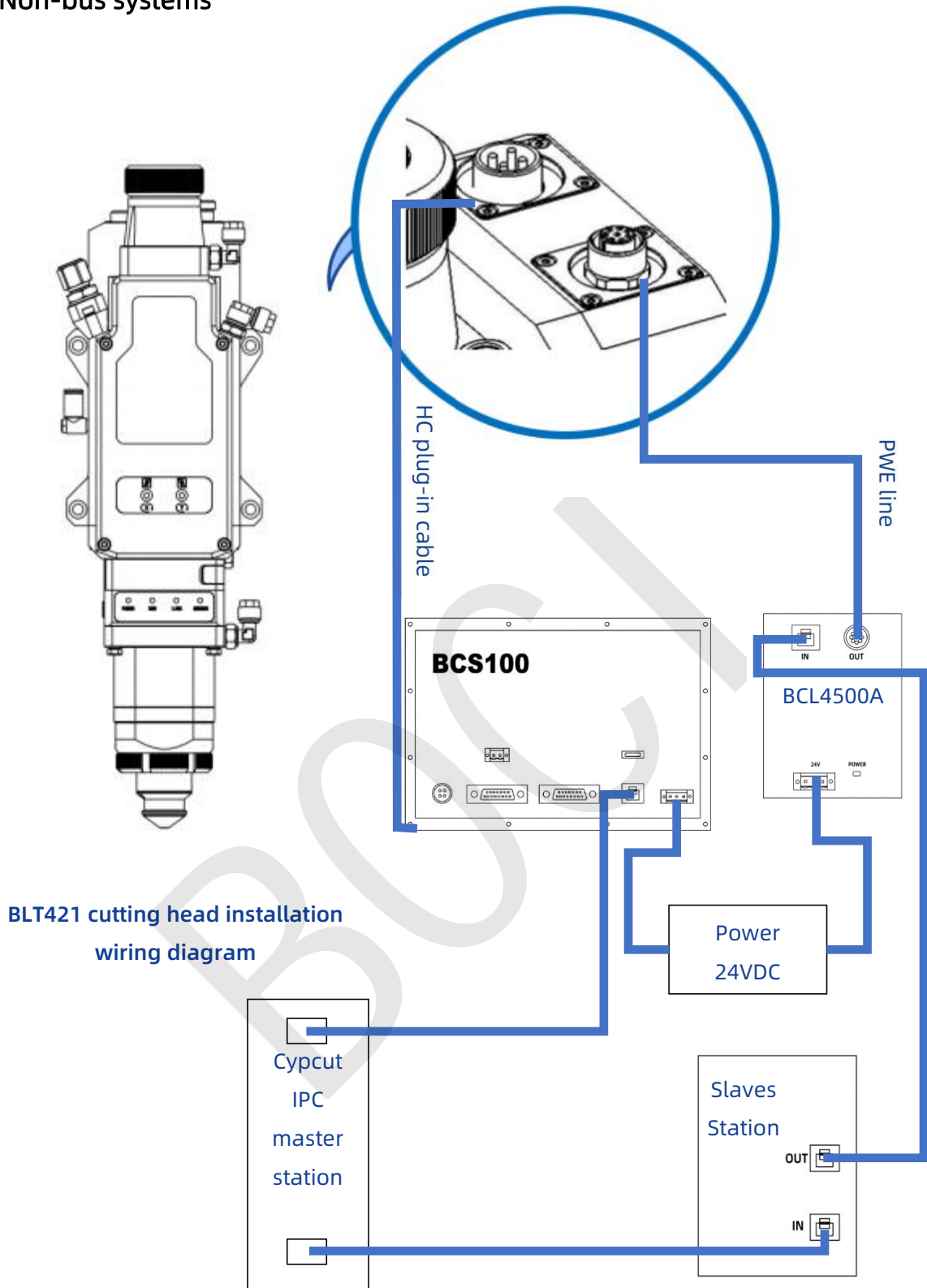

BLT421 cutting head installation wiring diagram



**Notice:**

- ◆ The above wiring operations should only be performed by trained and professional personnel.
- ◆ When the cutting head is connected to the BCL4500A, the BCL4500A must be powered off.

## 5. Cutting head installation

During the installation of the cutting head, dust or dirt may accidentally enter the cutting head, contaminate the optical lens, and affect its normal functions. To prevent dust or dirt from entering the cutting head, please refer to the following methods for the installation of the cutting head:

### 5.1 Preparation before operation

The following objects are required before operation:

- ◆ Cutting head;
- ◆ Clean workbench (clean workbench type: vertical purification; cleanliness level: ISO 5, 100; average wind speed  $\geq 0.4\text{m/s}$ );
- ◆ Cleaning kit: strong light flashlight, absolute ethanol (or IPA), dust-free purification cotton swab, dust-free cloth, compressed air dust removal tank (or air blower).

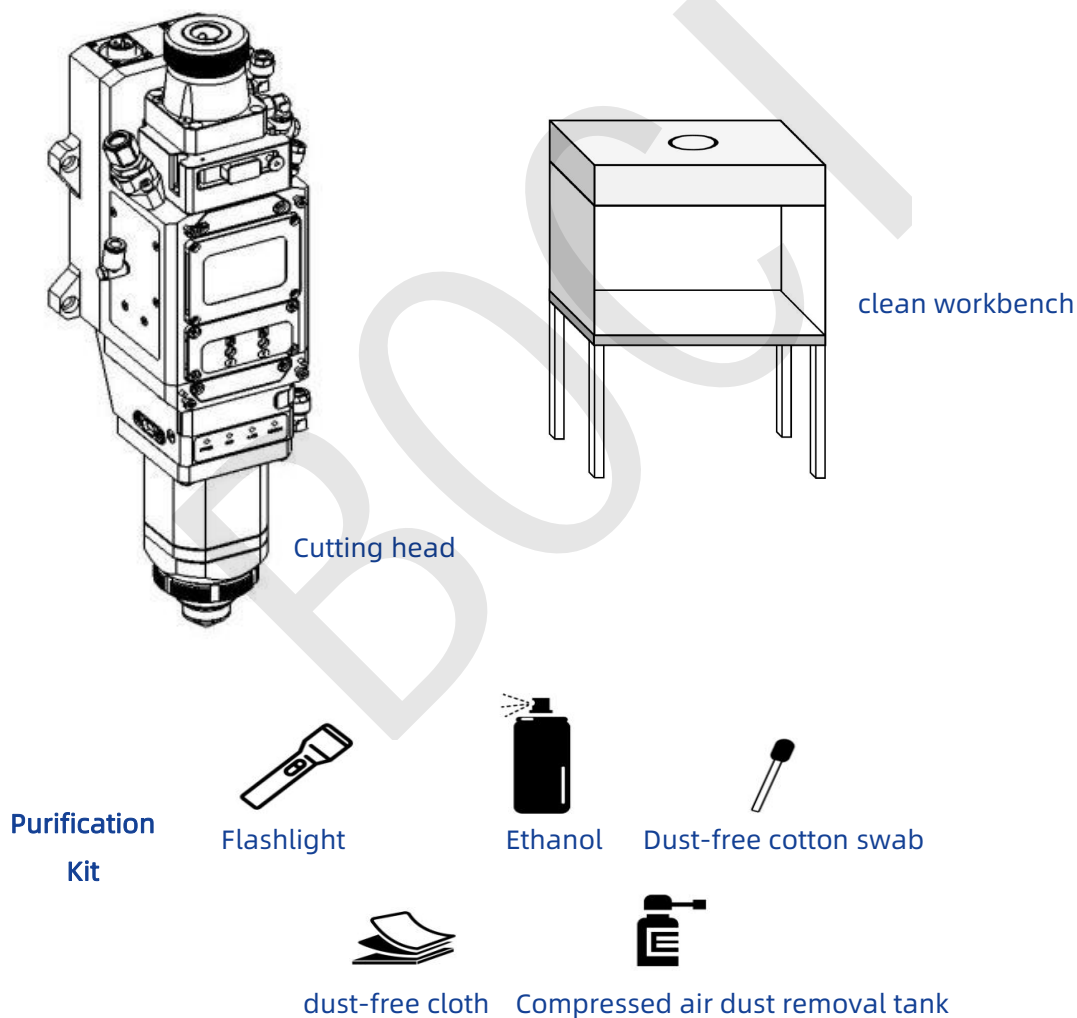

#### Notice:

- ◆ The above operations can only be carried out by personnel who have received appropriate training and have professional knowledge.
- ◆ In order to ensure the normal operation of the laser device and the safety of operators, please be sure to follow the relevant operating instructions.

### 5.2 Specific operation process

#### 5.2.1 Preparation of clean bench

Prepare the clean bench, start it up and ensure its functionality:

Clean table type: vertical purification; cleanliness class: ISO 5, 100; average wind speed  $\geq 0.4\text{m/s}$

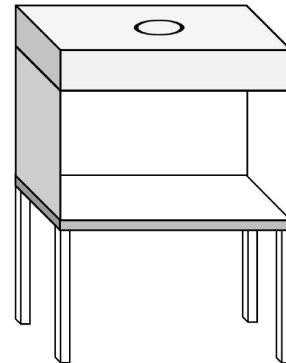

1. Check that the equipment is clean and qualified (checks the cleanliness of the dust particle counter ), and confirm that the FFU purification unit is within the validity period (measure the average wind speed in the working area, when the wind speed cannot reach  $0.3\text{m/s}$ , the FFU purification unit must be replaced);
2. Check whether each switch is running normally, and check whether the fan is running normally;
3. It is strictly forbidden to install unnecessary items in the clean working area to ensure that the clean air flow is not disturbed;
4. For clean workbenches that are newly installed or have not been used for a long time, please use a clean cloth and anhydrous ethanol to wipe them clean before use;

During operation:

1. Turn on the power, and pull the glass sliding door of the clean workbench to the lowest position (leaving a gap of about  $10\text{cm}$ );
2. Start the fan, it is recommended to purify the clean table for about 30 minutes in advance;
3. Turn on the light source of the clean workbench.

#### 5.2.2 The cutting head is placed in the clean workbench

Put the cutting head horizontally inside the clean workbench.

**Notice:**

- ◆ To prevent dust from contaminating the core area of the cutting head, please ensure the integrity of the special protective film/cap for the optical fiber interface before plugging and unplugging the optical fiber.

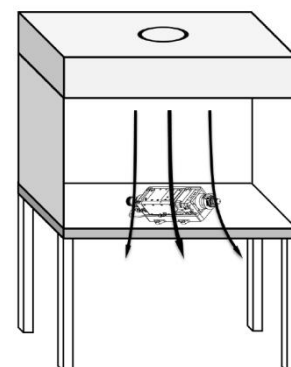

## 5.2.3 Clean and wipe the fiber interface of the cutting head

Wipe the fiber interface of the cutting head with a clean cloth and anhydrous ethanol.

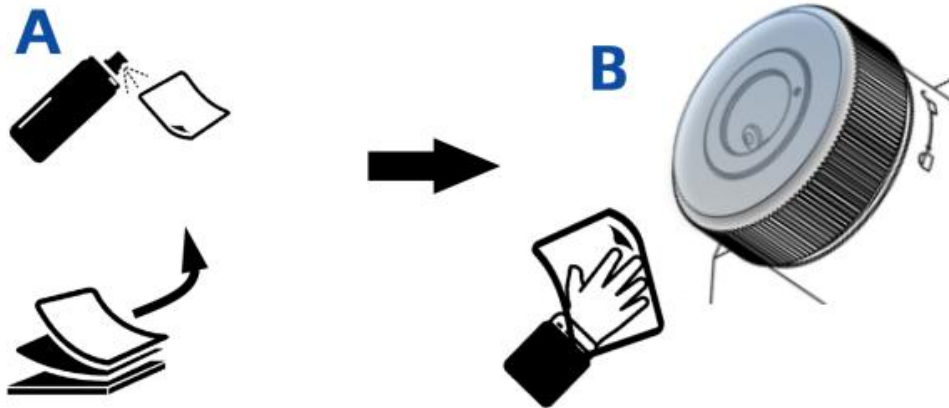

## 5.2.4 Check the laser fiber end face

Remove the protective cap of the laser fiber, and irradiate the end face of the fiber with a strong flashlight to observe whether there is any pollution; if it is clean, you can directly insert the fiber;



Check the fiber interface end face before insert

QBH

Compatible interfaces: Trumpf LLK-Q, IPG HLC-8/LC-8

## 5.2.5 Tear off the protective film/remove the protective cap

Remove the special protective cap/protective plug for the optical fiber interface on the cutting head.

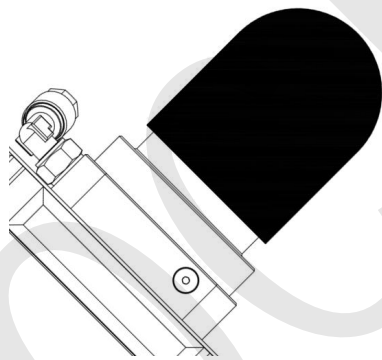
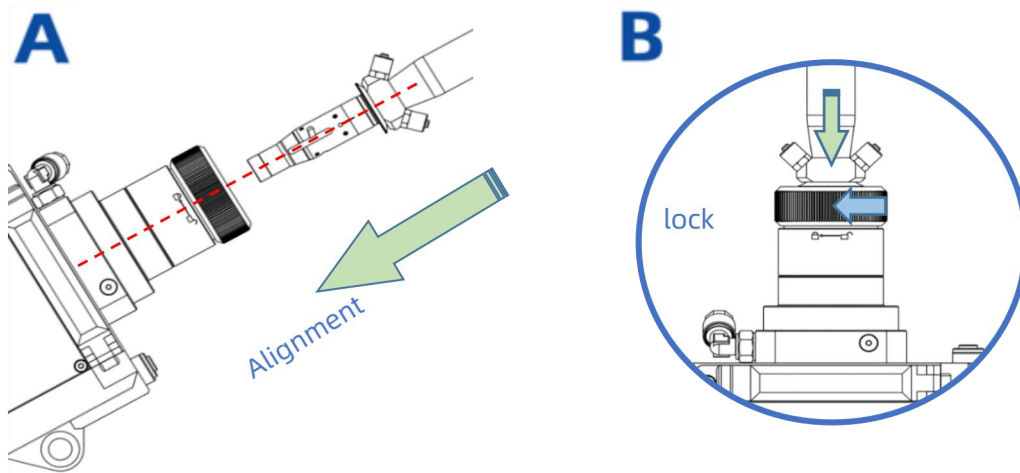

### 5.2.6 Insert the laser fiber interface into the cutting head

Align the fiber optic plug with the red dot, insert it into the unlocked fiber optic port, and ensure that it is inserted as far as it will go. Rotate the lock cap until it tightly locked.

### 5.2.7 Wrap and seal

After inserting the optical fiber, wrap and seal the interface between the optical fiber and the cutting head with tape.

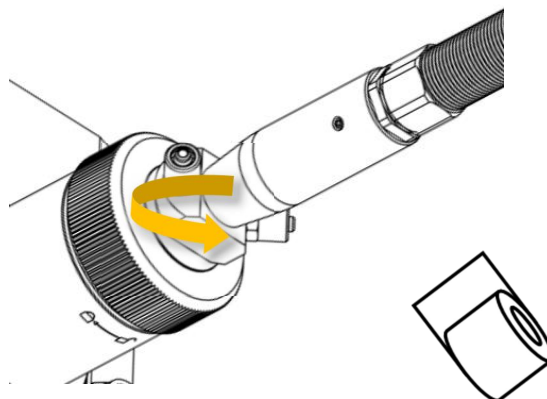



## Tape wrap seal



### Notice:

- ◆ To achieve effective sealing, it is recommended to wrap the tape at least three times for sealing.

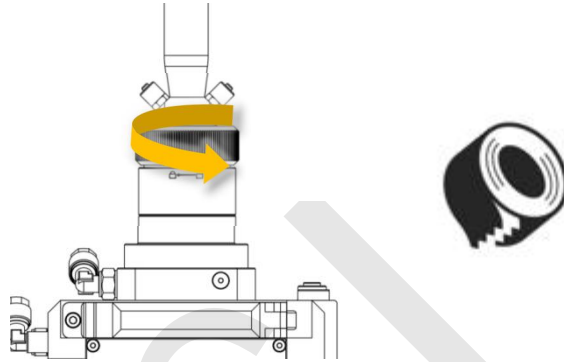

### 5.2.8 Mount the cutting head on the backplane

The cutting head can be installed on the Z-axis backplane of the machine tool through four screws A, B, C, and D. When fixing the cutting head on the machine, it must be ensured that the cutting head is locked and there is no obvious movement.

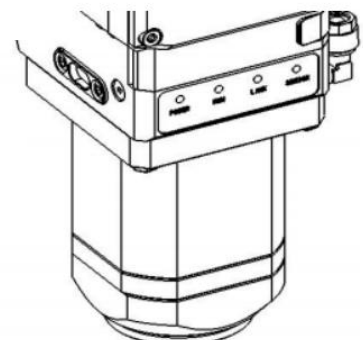
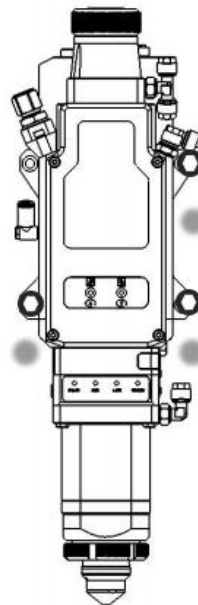

### 5.2.9 Installing the ceramic body and nozzle

Install the ceramic body and secure with the locking ring, then install the nozzle.



Tighten the nozzle on the ceramic

body by hand,



### 5.2.10 Beam centering

Adjust the XY centering knob to make the focal point in the center of the nozzle by low-power dotting.



The conditioned laser beam must be in the center of the nozzle.



Tape

X/Y  
adjustment

screw

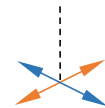
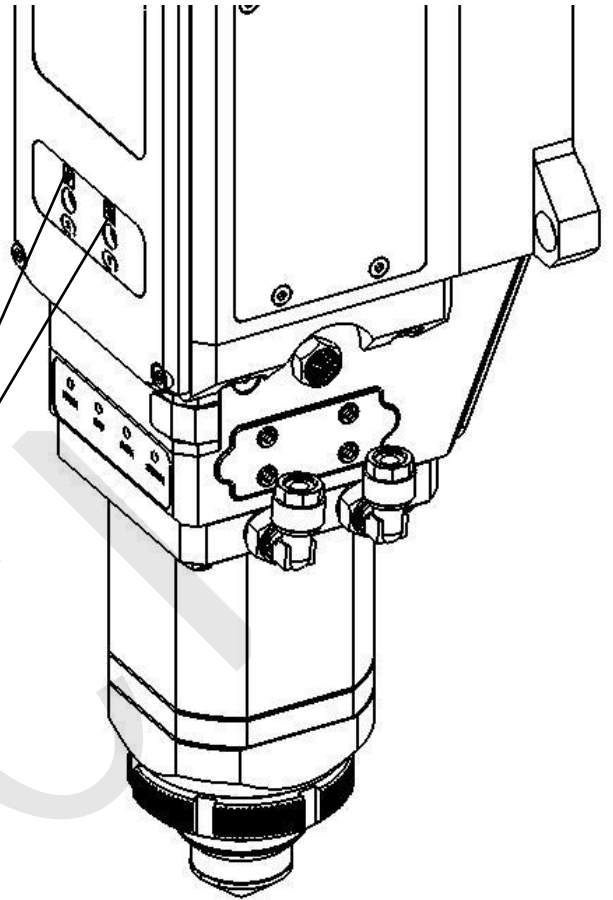

Relative position of laser beam

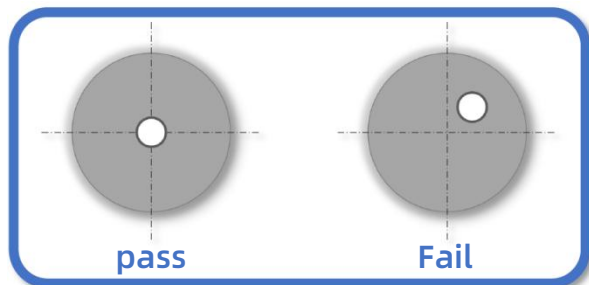



## Manual alignment operation:

1. Make sure the laser beam is turned off.
2. Place scotch tape under the nozzle.
3. Click to trigger a low-power laser pulse and assess the position of the laser beam relative to the nozzle through the penetration of the tape.
4. Adjust the X/Y centering screws to center the laser beam on the nozzle.

BOCI

## Appendix A - Care/Maintenance

### 1.1 Schematic diagram of product structure

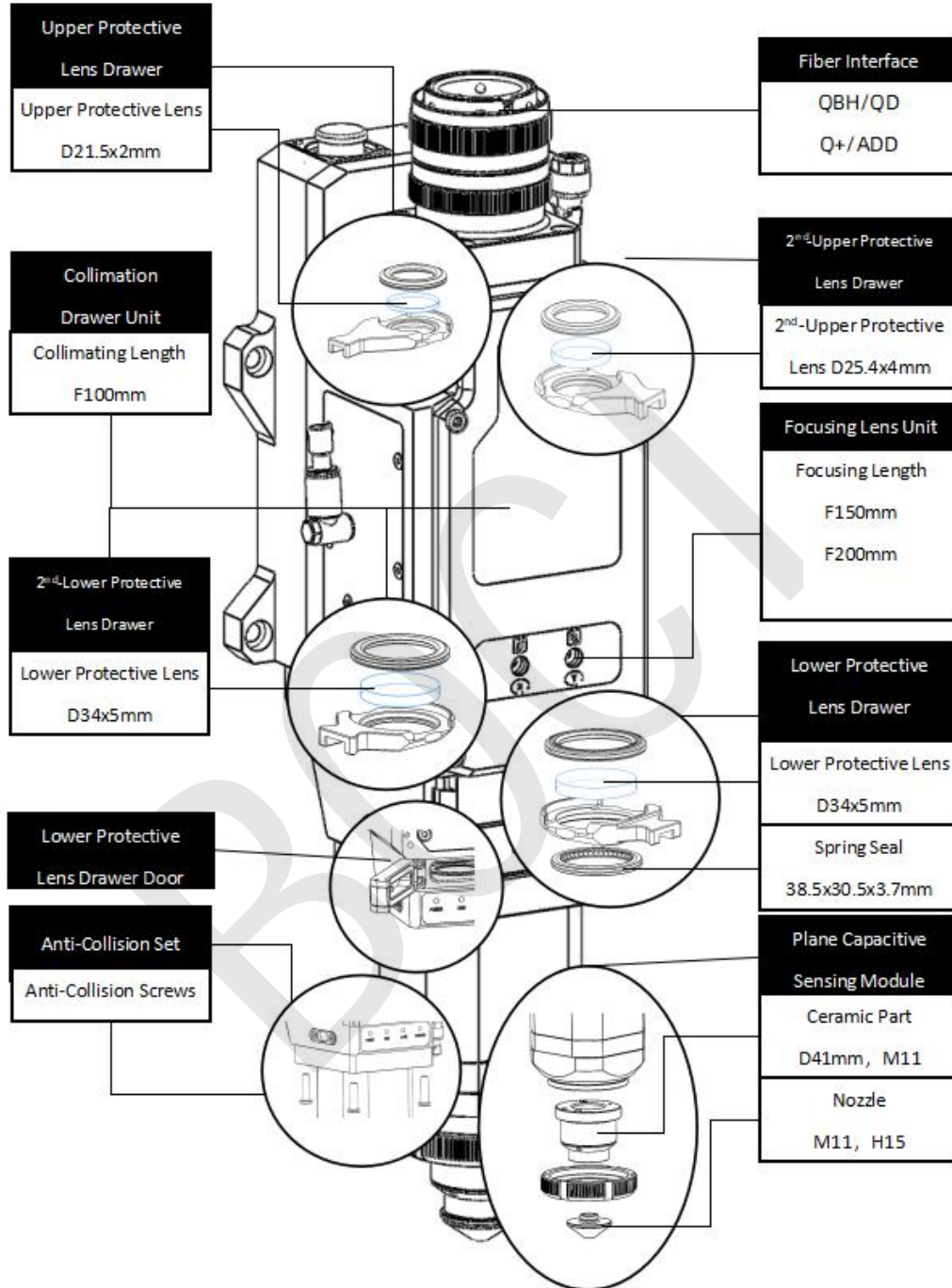

#### Notice:

- ◆ During the maintenance of cutting head accessories, dust or dirt may accidentally enter the cutting head and damage the product. Please pay attention to keep it clean during maintenance and replacement of accessories;
- ◆ The maintainable parts of different products will have different specifications. If you need to replace them, please contact your after-sales service personnel for specific models;
- ◆ Optical products have high quality requirements for maintainable accessories. Please ensure that the replacement and maintenance accessories are original accessories. Otherwise, there may be potential safety hazards.

## 1.2 Replace the upper protective lens

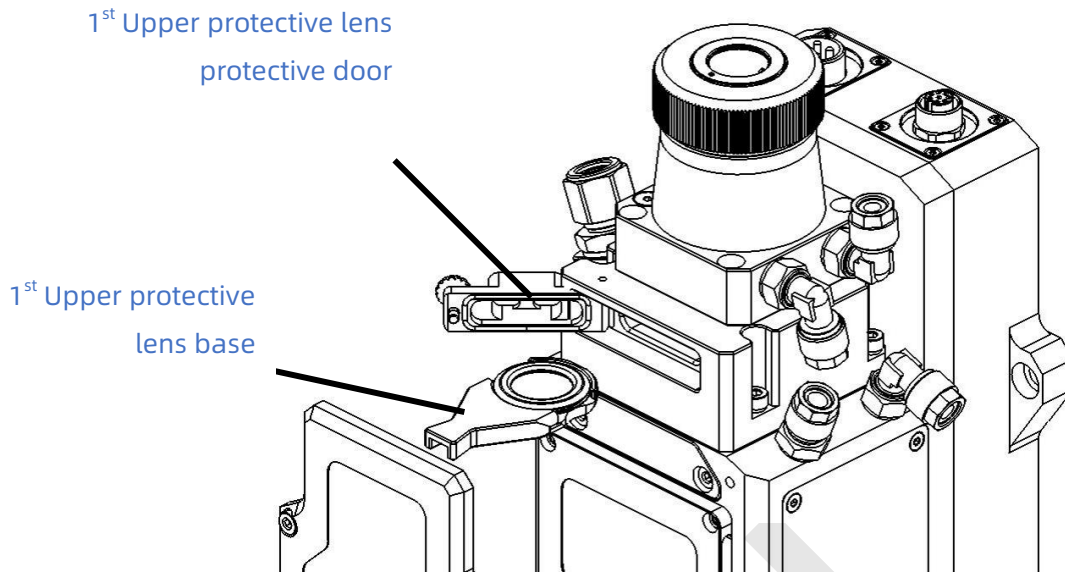

1. Open the protective door of the 1<sup>st</sup> upper protective lens;
2. Pull out the upper protective mirror drawer;
3. Close the protective mirror drawer door to prevent dust from entering;
4. Remove the pressure ring on the protective lens;
5. Replace the protective lens;
6. Open the upper protective mirror drawer protective door;
7. Insert the upper protective mirror drawer with lens into the cutting head.

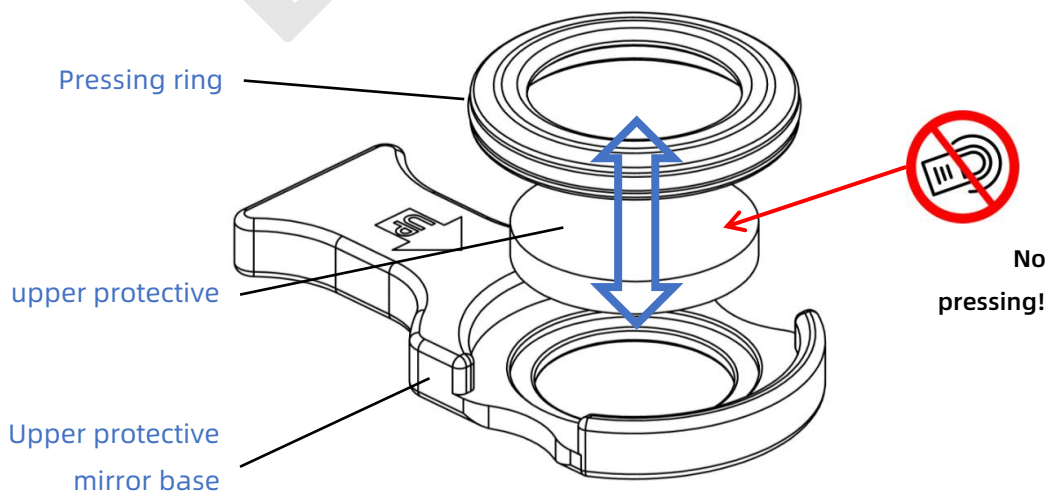

### 1.3 Replace the lower protective lens

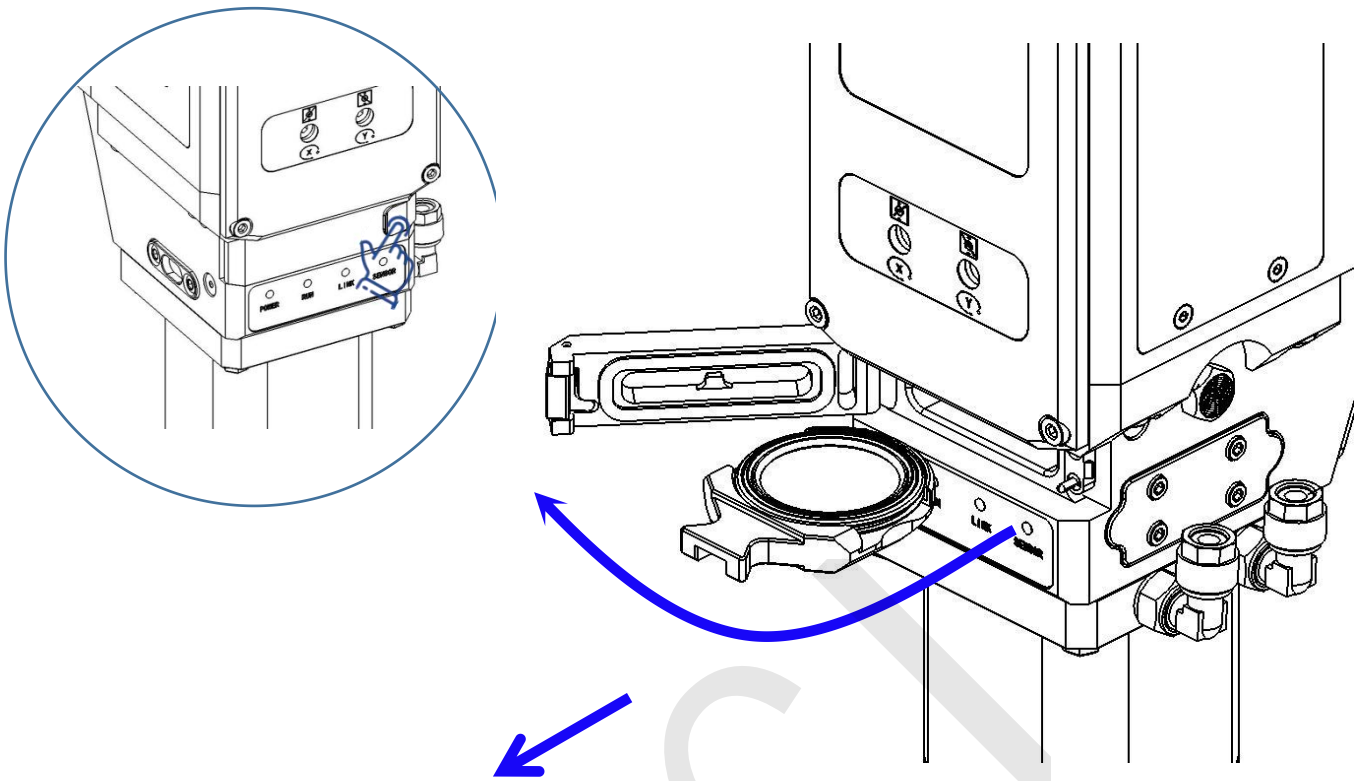

1. Press the buckle to open the protective door of the lower protective mirror drawer;
2. Pull out the lower protective mirror drawer;
3. Close the protective door of the lower protective mirror drawer to prevent dust from entering;
4. Remove the pressure ring on the protective lens;
5. Replace the lower protective lens;
6. Open the protective door of the lower protective mirror drawer;
7. Insert the lower protective mirror drawer with lens into the inside of the cutting head.

## Appendix B - Mechanical Dimensions

### 1.1 Cutting head installation size

